

Distributed by
Raymarine

Any reference to Raytheon or RTN in this manual should be interpreted as Raymarine. The names Raytheon and RTN are owned by the Raytheon Company.

SeaTalk Autopilot Hand-held Remote

Owner's Handbook

Document number: 81197-1
Date: July 2001

Autohelm, HSB (High Speed Bus), SailPilot, SeaTalk and SportPilot are registered trademarks of Raymarine Ltd.

Raymarine, AST (Advanced Steering Technology), AutoAdapt, AutoLearn, AutoRelease, AutoSeastate, AutoTack, AutoTrim, FastTrim, GyroPlus, RayGyro, RayPilot and WindTrim are trademarks of Raymarine Ltd.

Handbook contents © Raymarine Ltd 2001.

Introduction

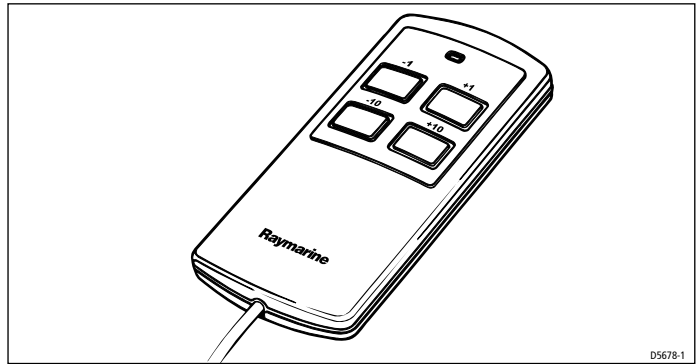

The SeaTalk autopilot hand-held remote (part number A15002) is suitable for use with all SeaTalk compatible autopilots.

It is supplied with:

- 6 m (19.5 ft) of cable with a pre-fitted SeaTalk plug
- a SeaTalk socket
- a bracket for storing the hand-held remote

Note: *The hand-held remote is not compatible with older Autohelm autopilots with an AH prefix (e.g. AH800). If you have any questions about compatibility, contact your nearest Raymarine dealer.*

Using the hand-held remote

Note: *You cannot use the hand-held remote to engage or disengage the autopilot. You will need to do this on the autopilot's control unit.*

When the autopilot is engaged, the hand-held remote allows remote control of the following autopilot functions:

Course changes

- use **-1** and **-10** to make 1° and 10° course changes to port
- use **+1** and **+10** to make 1° and 10° course changes to starboard

AutoTack (not SportPilots)

- press **-1** and **-10** together to AutoTack to port
- use **+1** and **+10** together to AutoTack to starboard

Connecting the hand-held remote

The hand-held remote is connected directly to Raymarine autopilots or instruments using SeaTalk (the Raymarine data interface system).

The remote is supplied with a waterproof plug and socket that can be installed anywhere a remote is required. The socket allows you to make connections directly to the autopilot or SeaTalk instrument, as described on the following pages.

Connections to Raymarine autopilots

Note: *In all of the following cases, the handheld remote can be connected via any available SeaTalk instrument or control unit rather than directly to the autopilot.*

ST1000+ and ST2000+ tiller pilots

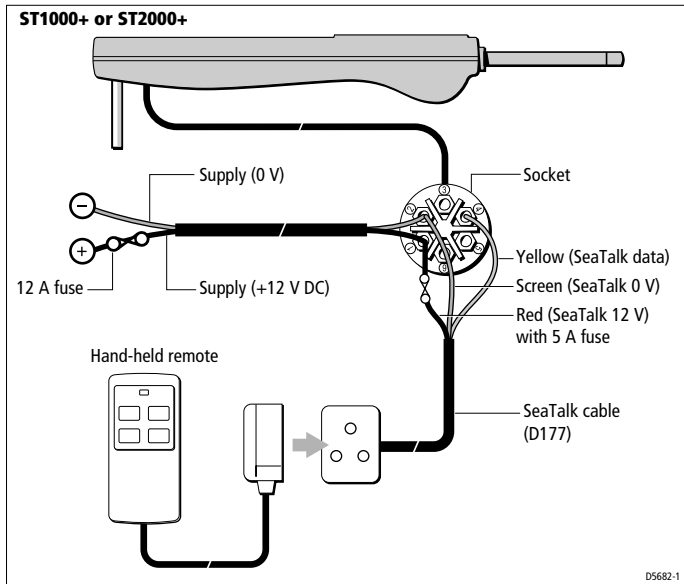

ST1000, ST2000 and ST3000 autopilots

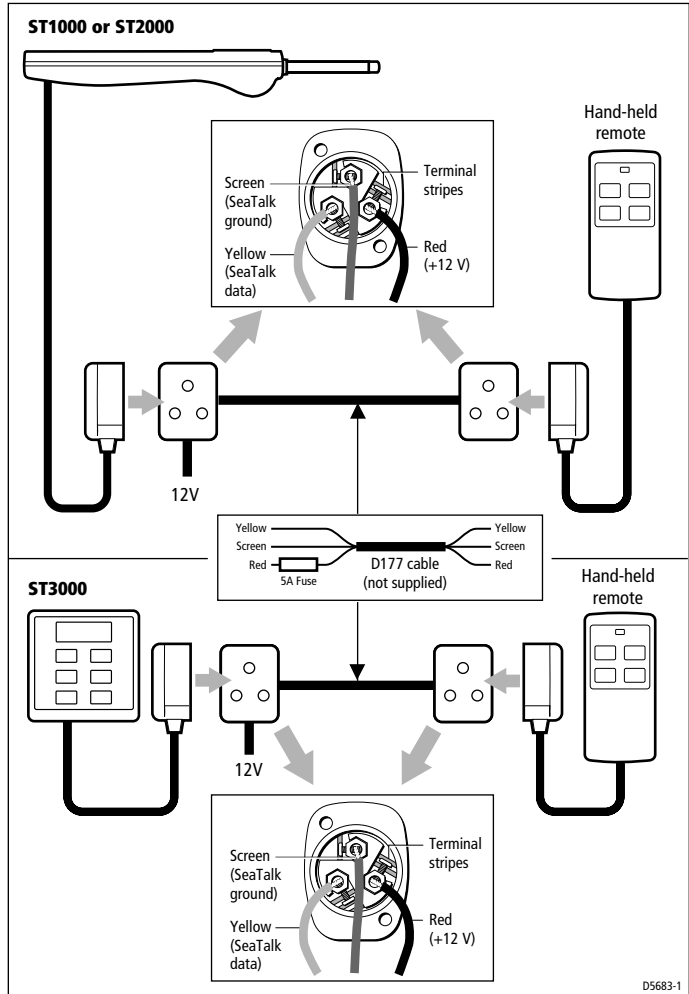

ST4000+ and ST5000+ autopilots

ST4000+ and ST5000+ control units have two parallel SeaTalk ports. You can connect the hand-held remote to either of these ports.

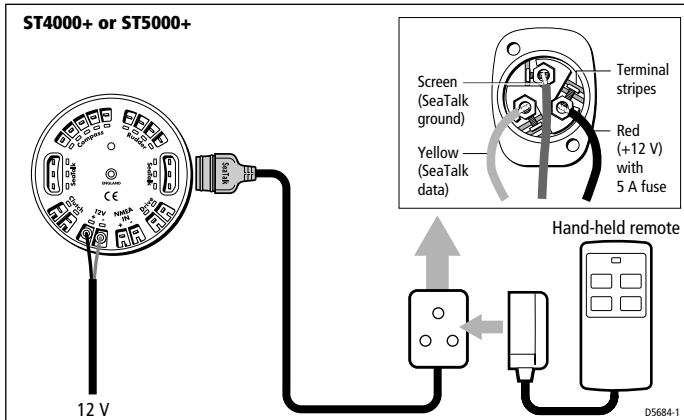

Note: If any other SeaTalk instruments are connected to the ST4000 or ST5000 control units, the red wire (+12 V) must be connected to a separate 12 V supply fitted with a 5 A fuse. It should NOT be connected to the control unit.

ST4000 and ST5000 autopilots

The main difference with older ST4000 and ST5000 control units is that the SeaTalk connections at the control unit will require spades (part number: D211).

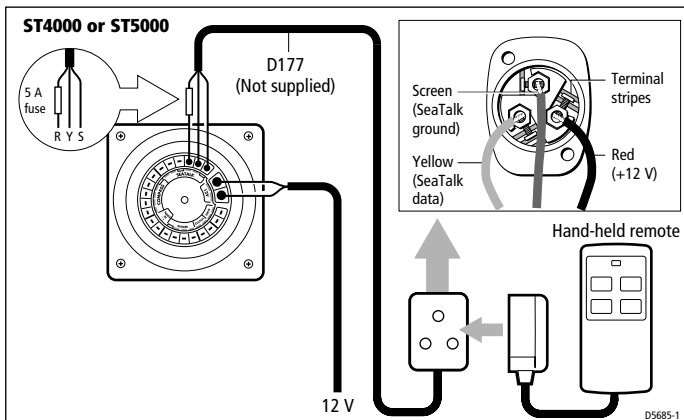

ST6000+, ST6001+, ST7000+ and ST7001+ pilots

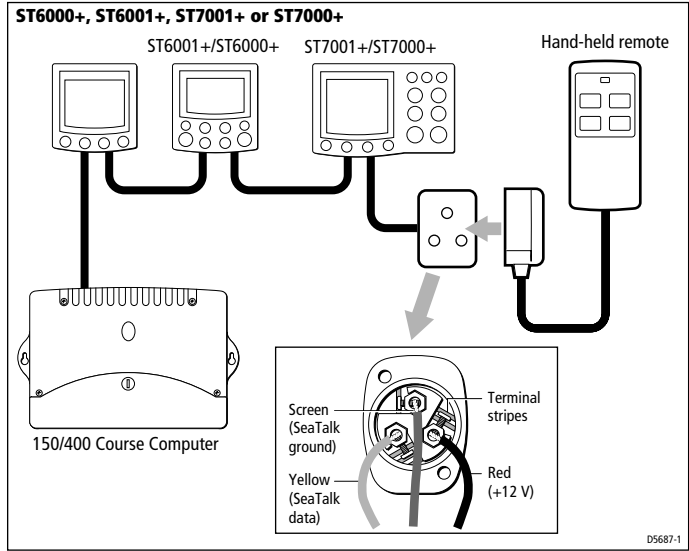

ST6000 and ST7000 autopilots

The main difference when connecting older ST6000 and ST7000 autopilots is that you will need a SeaTalk cable with round plugs.

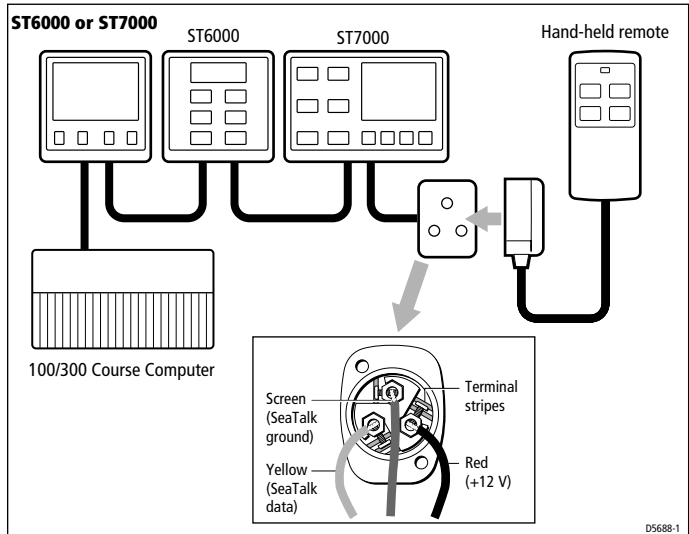

SportPilot and SportPilot Plus

To connect the hand-held remote to the SportPilot you will need to purchase an appropriate SeaTalk interface cable (D229). The red core should also be fitted with a 5 A fuse.

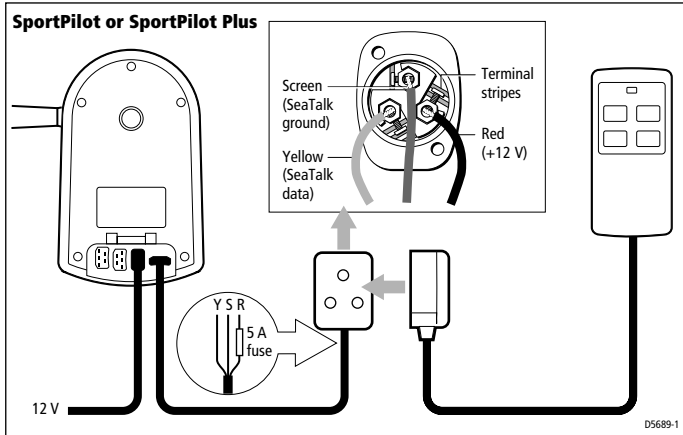

Note: *If you intend to locate the remote close to the SportPilot, the SportPilot's power cable has two additional wires (yellow and screen) that you can use to connect the SeaTalk socket to the pilot. However, a fused positive (+) connection from the power source to the socket will be required.*

SeaTalk cables

Because you can use the hand-held remote with a wide range of Raymarine autopilots, you will need to purchase the appropriate SeaTalk cable to connect the hand-held remote to the autopilot via the SeaTalk system.

Extension cables - flat moulded plugs at each end



Part no.	Type	Length
D284	Flat moulded plugs at each end	1 m (3 ft 3 in)
D285	Flat moulded plugs at each end	3 m (9 ft 10 in)
D286	Flat moulded plugs at each end	5 m (16 ft 5 in)
D287	Flat moulded plugs at each end	9 m (29 ft 6 in)
D288	Flat moulded plugs at each end	20 m (65 ft 6 in)

Conversion cables - flat moulded plug to round plug



Part no.	Type	Length
D187	Flat moulded plug to male round plug	0.15 m (6 in)
D188	Flat moulded plug to female round plug	0.3 m (12 in)

Extension cables - round plugs at each end



Part no.	Type	Length
D124	Male round plug to female round plug	1 m (3 ft 3 in)
D125	Male round plug to female round plug	3 m (9 ft 10 in)
D126	Male round plug to female round plug	6 m (19 ft 8 in)
D154	Male round plug to female round plug	9 m (29 ft 6 in)

Interface cables - bare wires at one or both ends

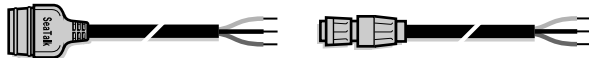

Part no.	Type	Length
D229	Flat moulded plug to bare wires	1 m (3 ft 3 in)
D179	Male round plug to bare wires	3 m (9 ft 10 in)
D181	Female round plug to bare wires	3 m (9 ft 10 in)
D177	Bare wires at both ends, in-line 5 A fuse	3 m (9 ft 10 in)

Installing the SeaTalk socket

1. Apply the template onto the bulkhead as required.
2. Drill the 18 mm ($45/64$ in) clearance hole and the two 2.5 mm ($3/32$ in) pilot holes.
3. Remove the template.
4. Cut and strip the SeaTalk cable (not supplied: see *page 9*).
5. Pass the cables through the bulkhead and wire to the socket, making sure the wires are connected to the correct pins.
6. Use the two self-tapping screws to attach the socket to the bulkhead.
7. Secure the cables at regular intervals using suitable cable ties.

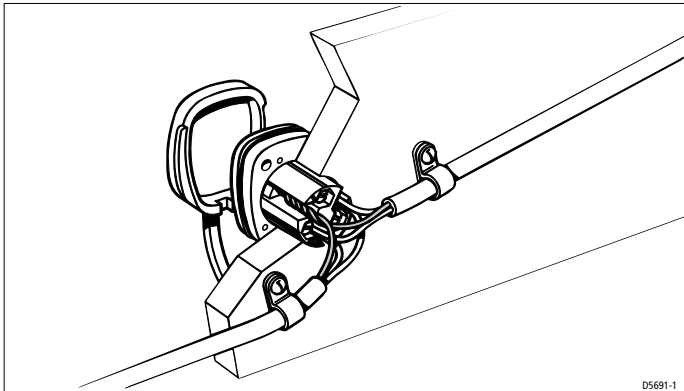

Note: *Should you require any spare parts, please refer to the spares list on page 12.*

Installing the hand-held remote bracket

The hand-held remote is supplied with a bulkhead-mounted storing bracket. This bracket should be attached to a convenient bulkhead using the 3 double-sided adhesive pads provided.

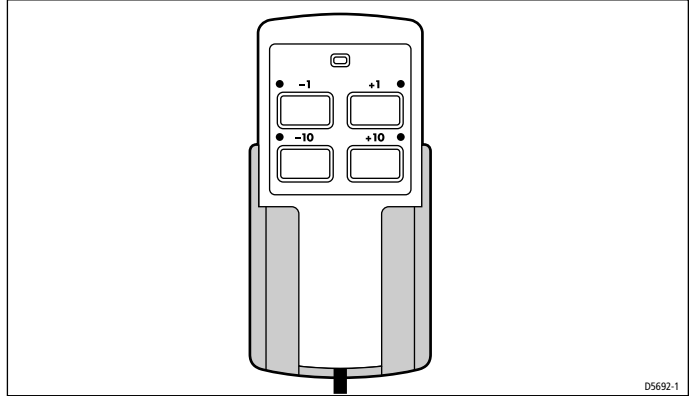

Note: Spare bulkhead brackets, part number D224, can be ordered from your dealer.

Fault Finding

All Raymarine products are subjected to comprehensive test procedures prior to packaging and shipment. In the unlikely event that a fault does occur, the following check list should help to cure any problem.

LED not illuminated

- No power supply – check the red lead for +12 V.
- Check the remote socket connections and the security of all SeaTalk connectors and cables.

No exchange of information between the hand held remote and the autopilot

- Open circuit SeaTalk bus – check the yellow (data) lead for fluctuating voltage.
- Check the remote socket connections and the security of all SeaTalk connectors and cables.

Unit does not operate autopilot

- Autopilot not in Auto mode.

Note: *No audible beep will be heard when operating the hand held remote.*

Spares List

The following items may be purchased from your local Raymarine dealer should you need them.

Part Number	Description
D161	SeaTalk socket assembly only
D162	Plug and socket assembly
D211	Spade connector kit for ST4000 and ST5000
D224	Hand-held remote storing bracket
D330	Socket O-ring

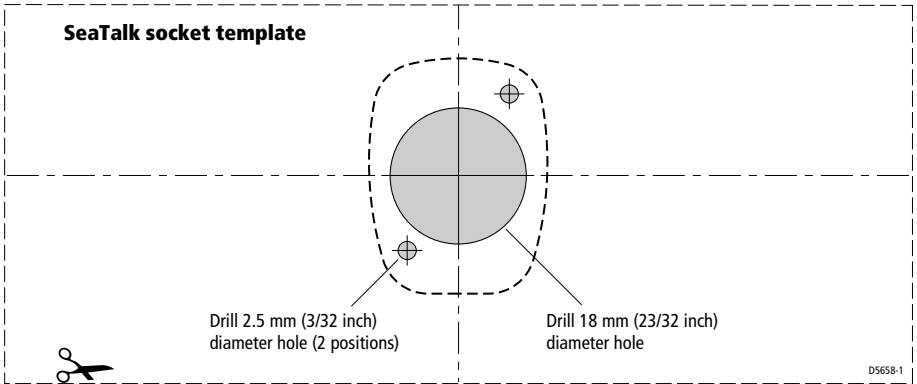

EMC Installation & Service Guidelines

IMPORTANT NOTE

All Raymarine equipment and accessories are designed to the best industry standards for use in the leisure marine environment.

When powered up, all electrical equipment produces electromagnetic fields. These can cause adjacent pieces of electrical equipment to interact with one another, with a consequent adverse effect on operation. In order to minimise these effects and enable you to get the best possible performance from your Raymarine equipment, these guidelines are provided to enable you to ensure minimum interaction between different items of equipment, i.e. ensure optimum Electromagnetic Compatibility (EMC).

The design and manufacture of Raymarine equipment and accessories conform to the appropriate EMC standards, but correct installation is required to ensure that performance is not compromised. Although every effort has been taken to ensure that they will perform under all conditions, it is important to understand what factors could affect the operation of the product. **Please keep this document for future reference.**

Safety

Some products generate high voltages, so never handle the cables/connectors when power is being supplied to the equipment.

Installation

These guidelines describe the conditions for optimum EMC performance, but it is recognised that it may not be possible to meet all of these conditions in all situations. To ensure the best possible conditions for EMC performance within the constraints imposed by any location, always ensure the maximum separation possible between different items of electrical equipment.

For **optimum** EMC performance, it is recommended that **wherever possible**:

- Raymarine equipment and cables connected to it are:
 - At least 1 m (3 ft) from any equipment transmitting or cables carrying radio signals e.g. VHF radios, cables and antennas. In the case of SSB radios, the distance should be increased to 2 m (7 ft).
 - More than 2 m (7 ft) from the path of a radar beam. A radar beam can normally be assumed to spread 20 degrees above and below the radiating element.
- The equipment is supplied from a separate battery from that used for engine start. Voltage drops below 10 V in the power supply to our products, and starter motor transients, can cause the equipment to reset. This will not damage the equipment, but may cause the loss of some information and may change the operating mode.

- Raymarine specified cables are used at all times. Cutting and rejoining these cables can compromise EMC performance and so must be avoided unless doing so is detailed in the installation manual.
- If a suppression ferrite is attached to a cable, this ferrite should not be removed. If the ferrite needs to be removed during installation it must be reassembled in the same position.

Suppression Ferrites

The following illustration shows typical cable suppression ferrites fitted to Raymarine equipment. Always use the ferrites supplied by Raymarine.

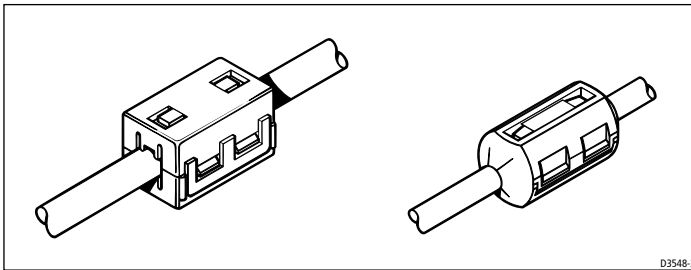

Connections to Other Equipment

If your Raymarine equipment is to be connected to other equipment using a cable not supplied by Raymarine, a suppression ferrite **MUST** always be fitted to the cable close to the Raymarine unit.

Check Before Going to Sea

Always check the installation before going to sea to make sure that it is not affected by radio transmissions, engine starting etc.

Servicing

Raymarine equipment should be serviced only by authorised Raymarine service technicians. They will ensure that service procedures and replacement parts used will not affect performance. There are no user serviceable parts in any Raymarine product.

Always report any EMC related problem to your nearest Raymarine dealer. We use such information to improve our quality standards.

In some installations it may not be possible to prevent equipment from being affected by external influences. In general this will not damage the equipment but it can lead to spurious resetting action, or momentarily may result in faulty operation.

Limited Warranty Certificate

Raymarine warrants each new Light Marine/Dealer Distributor Product to be of good materials and workmanship, and will repair or exchange any parts proven to be defective in material and workmanship under normal use for a period of 2 years/24 months from date of sale to end user, except as provided below.

Defects will be corrected by Raymarine or an authorized Raymarine dealer. Raymarine will, except as provided below, accept labor cost for a period of 2 years/24 months from the date of sale to end user. During this period, except for certain products, travel costs (auto mileage and tolls) up to 100 round trip highway miles (160 kilometres) and travel time of 2 hours, will be assumed by Raymarine only on products where proof of installation or commission by authorized service agents, can be shown.

Warranty Limitations

Raymarine Warranty policy does not apply to equipment which has been subjected to accident, abuse or misuse, shipping damage, alterations, corrosion, incorrect and/or non-authorized service, or equipment on which the serial number has been altered, mutilated or removed.

Except where Raymarine or its authorized dealer has performed the installation, it assumes no responsibility for damage incurred during installation.

This Warranty does not cover routine system checkouts or alignment/calibration, unless required by replacement of part(s) in the area being aligned.

A suitable proof of purchase, showing date, place, and serial number must be made available to Raymarine or authorized service agent at the time of request for Warranty service.

Consumable items, (such as: Chart paper, lamps, fuses, batteries, styli, stylus/drive belts, radar mixer crystals/diodes, snap-in impeller carriers, impellers, impeller bearings, and impeller shaft) are specifically excluded from this Warranty.

Magnetrons, Cathode Ray Tubes (CRT), TFT Liquid Crystal Displays (LCD) and cold cathode fluorescent lamps (CCFL), hailer horns and transducers are warranted for 1 year/12 months from date of sale. These items must be returned to a Raymarine facility.

All costs associated with transducer replacement, other than the cost of the transducer itself, are specifically excluded from this Warranty.

Overtime premium labor portion of services outside of normal working hours is not covered by this Warranty.

Travel cost allowance on certain products with a suggested retail price below \$2500.00 is not authorized. When/or if repairs are necessary, these products must be forwarded to a Raymarine facility or an authorized dealer at owner's expense will be returned via surface carrier at no cost to the owner.

Travel costs other than auto mileage, tolls and two (2) hours travel time, are specifically excluded on all products. Travel costs which are excluded from the coverage of this Warranty include but are not limited to: taxi, launch fees, aircraft rental, subsistence, customs, shipping and communication charges etc. Travel costs, mileage and time, in excess to that allowed must have prior approval in writing.

TO THE EXTENT CONSISTENT WITH STATE AND FEDERAL LAW:

(1) THIS WARRANTY IS STRICTLY LIMITED TO THE TERMS INDICATED HEREIN, AND NO OTHER WARRANTIES OR REMEDIES SHALL BE BINDING ON RAYMARINE INCLUDING WITHOUT LIMITATION ANY WARRANTIES OF MERCHANTABILITY OR FITNESS FOR A PARTICULAR PURPOSE.

(2) Raymarine shall not be liable for any incidental, consequential or special (including punitive or multiple) damages.

All Raymarine products sold or provided hereunder are merely aids to navigation. It is the responsibility of the user to exercise discretion and proper navigational skill independent of any Raymarine equipment.

Raymarine

Factory Service Centers

United States of America

Raymarine Inc
22 Cotton Road, Unit D
Nashua, NH 03063-4219, USA
Telephone: +1 603 881 5200
Fax: +1 603 864 4756
www.raymarine.com

Sales & Order Services

Telephone: +1 800 539 5539 Ext. 2333 or
+1 603 881 5200 Ext. 2333

Technical Support

Telephone: +1 800 539 5539 Ext. 2444 or
+1 603 881 5200 Ext. 2444
Email: techsupport@raymarine.com

Product Repair Center

Telephone: +1 800 539 5539 Ext. 2118

UK, Europe, Middle East, Far East

Raymarine Ltd
Anchorage Park, Portsmouth
PO3 5TD, England
Telephone: +44 (0)23 9269 3611
Fax: +44 (0)23 9269 4642
www.raymarine.com

Customer Support

Telephone: +44 (0)23 9271 4713
Fax: +44 (0)23 9266 1228

Email: techsupport@raymarine.com

Stick barcode label here

Purchased from

Purchase date

Dealer address

Installed by

Installation date

Commissioned by

Commissioning date

Owner's name

Mailing address

This portion should be completed and retained by the owner.